

VOLT 2017

CHEVROLET



FIND NEW ROADS™



TWITTER.COM/CHEVROLETCANADA



YOUTUBE.COM/CHEVROLETCANADA



FACEBOOK.COM/CHEVROLETCANADA

CHEVROLET.CA



Volt Premier in Siren Red Tintcoat
(extra-cost colour).



¹ 2017 Volt energy consumption and range ratings based on GM testing in accordance with Government of Canada approved test methods. Refer to vehicles.nrcan.gc.ca for details. Full charge required. Actual consumption, driving range and energy cost will vary based on temperature, driving conditions, and how you drive and maintain your vehicle. Even with a fully charged battery, the gas-powered electric generator may be required in cold ambient temperatures.



AUTOMOBILE JOURNALISTS
ASSOCIATION OF CANADA

**GOING GREEN HAS NEVER
BEEN THIS REVOLUTIONARY.**

It's not surprising that the Automobile Journalists Association of Canada (AJAC) named Volt the 2016 Canadian Green Car of the Year.

Volt offers a range of up to 85 electric kilometres¹ on a full charge. With impeccable style and advanced EV technologies like Regen on Demand™ and Location-Based Charging, going green doesn't get any more revolutionary than this.

FIND NEW ROADS™

EXTERIOR DESIGN



Volt Premier in Kinetic Blue Metallic (extra-cost colour).

LOOKS CAN GO JUST AS FAR. That's the beauty of it. The muscular shape, along with the upper and lower grille pads, give Volt an identity of its own. From the finely tuned exterior and LED signature daytime running lamps to the redesigned grille, there's brilliance in every detail.

EXPERIENCE EFFICIENCY. Aesthetically and aerodynamically, it works together. Deliberate contours and expressive proportions form a bold, confident stance and offer optimal efficiency. So staring is understandable, but get inside and you'll find the journey is even more rewarding.

PRETTY SMART. Advanced EV technologies such as Regen on Demand offers an innovative way to recharge while driving, and the Power Flow screen displays the current system's operating condition, showing the power flow between the high-voltage propulsion battery, electric drive unit and engine.



1. YOU HAVE OPTIONS. Volt offers two trim levels with unique wheels and multiple colour choices. So it's easy to make Volt match your own unique personality.

2. WINK, WINK. LED front signature lighting enhances the eye-catching design with illuminating detail. Nothing but bright roads ahead for you.

3. IMPRESSIVE CURVES. Volt was expertly carved and shaped with diligence and precision all in the name of performance and efficiency. Plus, its wide stance contributes to nimble handling.



INTERIOR DESIGN



Volt Premier interior in Jet Black with available features.

WELCOME. Inside, you'll see everything about Volt is visually stunning. The beautifully crafted interior features standard heated front bucket seats to keep you comfortably in place, while twin-needle stitching provides a luxurious appeal. A refined driving experience is achieved before you even take off.

YOUR INVITATION TO INNOVATION. Thoughtfully designed and tailored to meet your needs, Volt welcomes you with comfort. Detail is taken to another level with intuitiveness and ingenuity, so everything is centred around you.

ONE TOUCH GIVES YOU ALL ACCESS. A colour touch-screen in the centre of the instrument panel puts everything you need within reach. Energy screens, certain features from your phone, music, infotainment and other controls – it's all right here, and easily accessible.

DEP
DEALER ePROCESS



1. TAKE THE CHILL AWAY. Heated front bucket seats are standard on both LT and Premier models. Rear (outboard) heated seats are also included on the Premier model.



2. COMFORTABLY IN CONTROL. The standard leather-wrapped heated steering wheel on Volt includes switches that allow you to make and receive calls, adjust the audio system or cruise control and engage the Regen on Demand feature all while keeping your hands on the wheel.



3. VOLT STANDS OUT AND FITS IN. You'll have plenty of space to put your stuff. With functional cargo space and seating accommodations for five passengers, there's no room for compromise.



THE ULTIMATE BUILT-IN Wi-Fi HOTSPOT. Chevrolet is the first and only car company to offer OnStar 4G LTE with built-in Wi-Fi¹ hotspot to cars, trucks and crossovers, providing the ability to seamlessly connect your smart devices and vehicles to the Internet. It offers great signal quality and bandwidth for up to seven devices.

Apple CarPlay™ COMPATIBILITY.² Take some of your favourite compatible iPhone® features and put them on your vehicle's touch-screen display in a smart, simple manner. Access your Phone, Music, Maps, and Messages, as well as some of your other favourite apps.

INTUITIVE INTERIOR. If it feels like you and Volt have an instant connection, it's because you do. Advanced EV and entertainment technologies make driving Volt as seamless and convenient as possible. So, as you get to know Volt, Volt learns about you based on the way you drive.

SIRI EYES FREE. If you have a compatible iPhone, you can use Siri® Eyes Free³ to compose and read text messages, access your calendar, get game scores, check for weather and more.

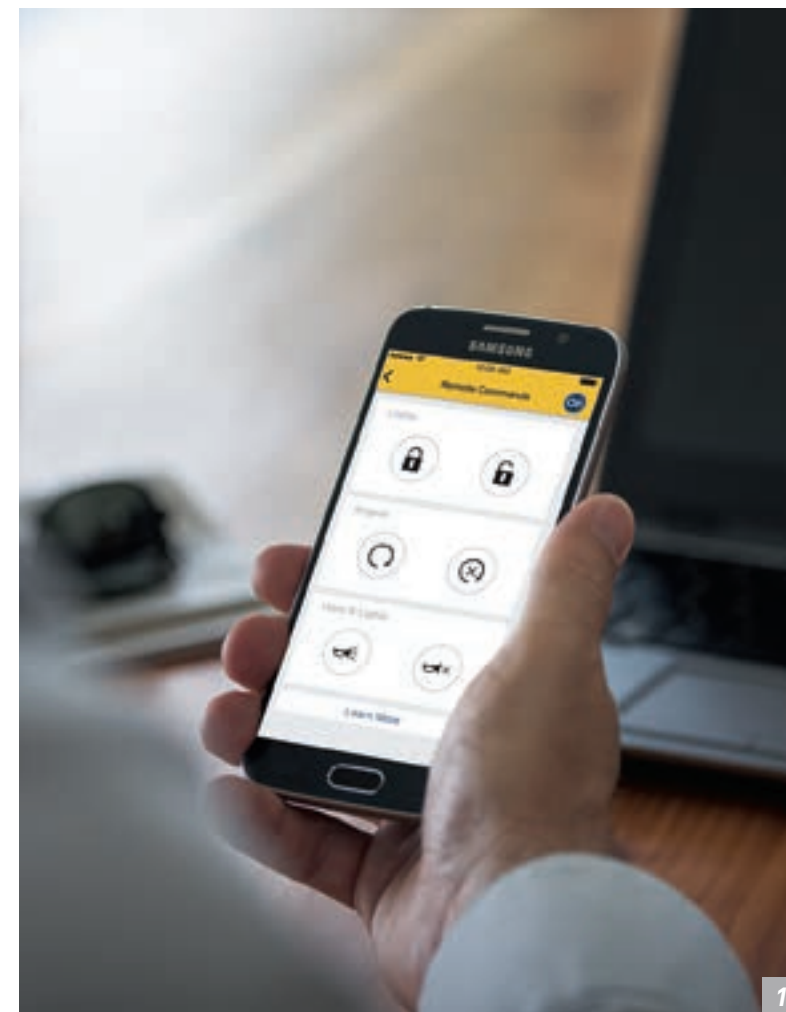

1. myChevrolet™ MOBILE APP.⁴

Now you can control your car from anywhere you have a signal, with an app that lets you remote start⁵ your vehicle and send destinations⁶ to your navigation system (if equipped). You can also manage your Wi-Fi hotspot, unlock your doors⁸, and monitor your charge level and efficiency. And you can even find the nearest charging station – all from your smartphone (if equipped with in-dash navigation). You're connected wherever you go.

2. MAKING SMARTPHONES SMARTER.

With an available wireless charging feature⁷, Volt makes it easier to keep your smartphone fully powered. Simply equip your phone with an accessory backplate or case, so you can keep your phone charged on the go.

3. EASY ACCESS TO YOUR SMARTPHONE.

With Android Auto™ compatibility², you can interact with select smartphone apps. This system takes some of your compatible Android™ phone's features and puts them on the Chevrolet MyLink® display in a smart, simple manner. You can access your phone, text messages, music, navigation and more.

¹ Includes data plan trial for 3 months or 3 GB, whichever comes first. Visit onstar.ca for coverage maps, details and system limitations. Service plan required. Available 4G LTE with Wi-Fi hotspot requires WPA2 compatible mobile device and data plan. Data plans provided by AT&T. Services vary by model, service plan, conditions as well as geographical and technical restrictions. OnStar with 4G LTE connectivity is available on select vehicle models and in select markets. Vehicle must be started or in accessory mode to access Wi-Fi. ² Vehicle user interfaces are products of Apple and Google and their terms and privacy statements apply. Requires compatible smartphone and data plan rates apply. ³ Requires Chevrolet MyLink and compatible iPhone running iOS 6 or later. ⁴ Available on select Apple and Android devices. Some features may require a paid OnStar service plan. Features and capability may vary by vehicle, device, conditions as well as geographical and technical restrictions. Device data connection required. ⁵ Visit onstar.ca for coverage maps, details and system limitations. Services vary by model, conditions as well as geographical and technical restrictions. Unlock feature requires automatic locks. Remote start requires factory-installed and -enabled remote start system. ⁶ Requires Basic Plan and navigation system to send directions through the mobile app. Turn-by-Turn directions and Destination Download also available through an advisor with the Guidance Plan or Navigation Add-On Plan. Visit onstar.ca for coverage maps. Services vary by model. ⁷ The system wirelessly charges one PMA- or Qi-compatible mobile device. Some devices require an adaptor or back cover. To check for phone or other device compatibility, visit chevrolettotalconnect.ca for details. ⁸ Full functionality requires compatible Bluetooth and smartphone, and USB connectivity for some devices.

PERFORMANCE



Volt Premier in Kinetic Blue Metallic (extra-cost colour).

TWO CHARGE OPTIONS. An available Level 2, 240-volt charging system can replenish the battery in 4.5 hours (professional installation required). There is also a standard 120-volt portable cord that can charge the battery in approximately 13 hours¹

THERE'S A SCREEN FOR EVERYTHING. Want to know how much power you will use? Volt has a screen for that. The Energy Usage Score screen shows you how well you use energy. Get quick access to valuable data, such as your battery level, charge settings, range estimation and more.

LOCATION-BASED CHARGING. Volt makes charging efficient, with home and away settings for recharging. This feature allows you to take advantage of off-peak electricity rates when you're at home but always begins charging immediately when you're away.

REGEN ON DEMAND. Through a steering wheel-mounted paddle, Regen on Demand seamlessly transfers the kinetic energy from the motion of Volt and stores it in the battery while slowing down the vehicle.

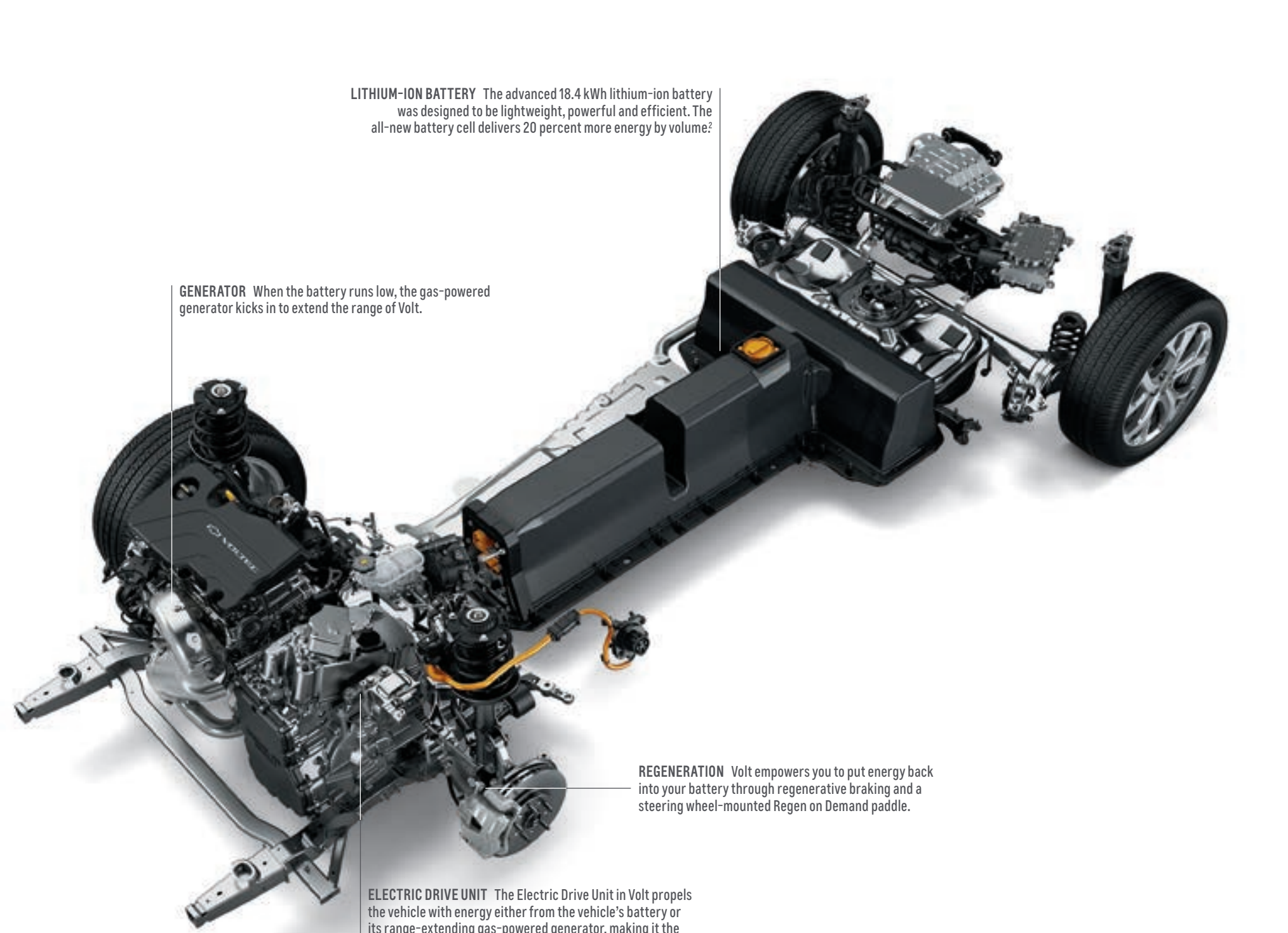

LITHIUM-ION BATTERY The advanced 18.4 kWh lithium-ion battery was designed to be lightweight, powerful and efficient. The all-new battery cell delivers 20 percent more energy by volume.²

GENERATOR When the battery runs low, the gas-powered generator kicks in to extend the range of Volt.

REGENERATION Volt empowers you to put energy back into your battery through regenerative braking and a steering wheel-mounted Regen on Demand paddle.

ELECTRIC DRIVE UNIT The Electric Drive Unit in Volt propels the vehicle with energy either from the vehicle's battery or its range-extending gas-powered generator, making it the electric vehicle with a backup plan.

¹ Using the 120-volt portable charger will take approximately 19 hours at the default 8-amp setting and can be reduced to 13 hours at the 12-amp setting. Actual time may vary with temperature. ² Comparison to initial 2011 Volt battery cell.

**PARALLEL PARK LIKE A PRO,
WITH AVAILABLE AUTOMATIC PARKING ASSIST.**



1. PARENTS, BREATHE.

Teen Driver technology helps encourage safe driving habits for new drivers in a number of ways, including muting the audio system when front-seat occupants are not wearing their safety belts and giving audible and visual warnings when the vehicle is travelling over the predetermined speed.

2. ONSTAR® AUTOMATIC CRASH RESPONSE!

In a crash, built-in sensors can alert a specially trained OnStar advisor, who can be connected into your Volt to see if you need help – even if you can't ask for it. Advisors can use GPS technology to pinpoint your location and request emergency help. OnStar Automatic Crash Response is included in the OnStar² Guidance Plan, which is standard for six months.

3. INTELLIGENT AIRBAGS.

Volt features 10 standard airbags³ and a collision sensor system designed to deploy the airbags that are needed.

1 Visit onstar.ca for vehicle availability, details and system limitations. OnStar acts as a link to existing emergency service providers. Not all vehicles may transmit all crash data.
2 Visit onstar.ca for coverage maps, details and system limitations. Service plan required. Available 4G LTE with Wi-Fi hotspot requires WPA2 compatible mobile device and data plan. Data plans provided by AT&T. Services vary by model, service plan, conditions as well as geographical and technical restrictions. OnStar with 4G LTE connectivity is available on select vehicle models and in select markets. Vehicle must be started or in accessory mode to access Wi-Fi. 3 Airbag inflation can cause severe injury or death to anyone too close to the airbag when it deploys. Be sure every occupant is properly restrained. A NOTE ON CHILD SAFETY: Always use safety belts and the correct child restraint for your child's age and size, even with airbags. Even in vehicles equipped with the Passenger Sensing System, children are safer when properly secured in a rear seat in the appropriate infant, child or booster seat. Never place a rear-facing infant restraint in the front seat of any vehicle equipped with an active frontal airbag. See the Owner's Manual and the child safety seat instructions for more safety information.

SAFETY STARTS WITH YOU. Safety features are no substitute for the driver's responsibility to operate the vehicle in a safe manner. The driver should remain attentive to traffic, surroundings and road conditions at all times. Read the Volt Owner's Manual for important feature limitations and information.

WE'VE GOT YOUR BACK. AND SIDES. AND FRONT.

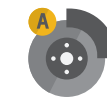

LOW SPEED FORWARD AUTOMATIC BRAKING. If the vehicle is travelling at low speeds and the system determines a front-end collision situation is imminent with a detected vehicle ahead, and the driver has not already applied the brakes, this available system automatically engages the brakes to help reduce the collision's severity. The system may even help avoid contact at very low speeds.



FORWARD COLLISION ALERT. This available feature continually monitors how close your vehicle is to the vehicle in front of you. If the system determines that a front-end collision with a detected vehicle is imminent, it alerts the driver to a potential crash. It also warns the driver if their Volt is following a detected vehicle too closely.



LANE KEEP ASSIST. At speeds above 60 km/h (37 mph), the available camera-based system monitors road lines and will gently turn the steering wheel if the vehicle begins changing lanes without the use of a turn signal.



SIDE BLIND ZONE ALERT. This available feature uses radar sensors on both sides of the vehicle to help warn you when vehicles are in your side blind zone areas and indicates their presence with LED-lit symbols in the exterior mirrors.



LANE CHANGE ALERT. Working with available Side Blind Zone Alert, available Lane Change Alert employs radar sensors in the rear corners of the vehicle to help detect and alert the driver to fast-approaching vehicles in the adjacent lanes from up to 25 m (82 ft.) away, not just in the side-view mirror blind zones.



REAR CROSS TRAFFIC ALERT. Available Rear Cross Traffic Alert helps alert drivers to approaching traffic when backing up. If a vehicle is detected, the driver is warned with visual and audible alerts.



REAR VISION CAMERA. The standard rear vision camera with dynamic guiding lines uses the Chevrolet MyLink 8-in. diagonal colour touch-screen display to show the area behind your Volt while you are backing up.



AUTOMATIC PARKING ASSIST. This available, ingenious system enables Volt to detect viable parking spaces, determine approach angles and take over the steering to neatly manoeuvre into an available space. Throttle, brake and gear selection input is still required by the driver, but the vehicle steers itself into any suitable-sized parallel or perpendicular (90-degree) parking spot.



FRONT AND REAR PARK ASSIST. Ideal when pulling into a parking spot at low speeds, the available system senses stationary objects and warns you if an object is too close. As you shift into Reverse, the rear vision camera automatically displays a live image of the area behind the vehicle on the Chevrolet MyLink screen and includes guiding lines to help when backing up.



INTELLIBEAM HEADLAMPS. When oncoming headlamps are sensed or when tail lamps are detected in front of you, the available IntelliBeam® high beam assist intuitively adjusts between low and high beams.



FULL-SPEED ADAPTIVE CRUISE CONTROL. This available feature enhances cruise control by allowing the vehicle to automatically follow a detected vehicle at the driver-selected following gap, reducing the need to frequently brake and accelerate.



CHARGING



Available 240-volt charging station.

Please see your Chevrolet Volt dealer for complete information and details on available 240-volt home charging stations and any provincial incentives.

DIMENSIONS



1539 mm (60.6 in.)
1808 mm (71.2 in.)



2695 mm (106.1 in.)
4582 mm (180.4 in.)



1570 mm (61.8 in.)

INTERIOR, MM (IN.) FRONT/REAR

Headroom	960/909 (37.8/35.8)
Legroom	1069/881 (42.1/34.7)
Shoulder Room	1435/1351 (56.5/53.2)
Hip Room	1364/1303 (53.7/51.3)

CAPACITIES

Cargo Area, L (cu. ft.)	300 (10.6)
Fuel Tank, L (imp. gal.)	34 (7.4)
CURB WEIGHT, KG (LB.)	
Volt	
- LT	1596 (3519)
- Premier	1607 (3543)

¹ Included and only available with Driver Confidence II Package. ² Replaces low-speed Forward Automatic Braking when available Adaptive Cruise Control is ordered. ³ Visit onstar.ca for coverage maps, details and system limitations. Service plan required. Available 4G LTE with Wi-Fi hotspot requires WPA2 compatible mobile device and data plan. Data plans provided by AT&T. Services vary by model, service plan, conditions as well as geographical and technical restrictions. OnStar with 4G LTE connectivity is available on select vehicle models and in select markets. Vehicle must be started or in accessory mode to access Wi-Fi. ⁴ Included and only available with Driver Confidence Package. ⁵ Requires available Driver Confidence Package and Driver Confidence II Package. ⁶ Visit chevrolettotalconnect.ca to find out which phones are compatible with the vehicle. ⁷ Full functionality requires compatible Bluetooth and smartphone, and USB connectivity for some devices. ⁸ Requires compatible iPhone running iOS 6 or later. ⁹ Vehicle user interfaces are products of Apple and Google and their terms and privacy statements apply. Requires compatible smartphone and data plan rates apply. ¹⁰ At time of printing, detailed map coverage is available for most major urban areas of the United States and for certain metropolitan areas of Canada (Vancouver, Calgary, Edmonton, Winnipeg, Windsor, London, Toronto, Ottawa, Montreal, Quebec City and Halifax). Coverage is significantly limited outside these areas. ¹¹ SiriusXM Traffic is available in select markets and requires SiriusXM satellite radio service. SiriusXM satellite radio and SiriusXM Traffic subscriptions are sold separately or as a package after the 3-month trial period. If you decide to continue service after your trial, the subscription plan you choose will automatically renew thereafter and you will be charged according to your chosen payment method at then-current rates. Fees and taxes apply. To cancel you must call 1-888-539-7474. For more information, visit siriusxm.ca/traffic. ¹² The OnStar Basic Plan is available for 5 years from the delivery date of the eligible new 2017 model year to the original owner and is transferable to subsequent owners for the remaining term. It includes the monthly Diagnostics Report emails (capabilities vary by model), Dealer Maintenance Notification, access to select vehicle mobile app features and more. This plan does not include emergency, security or navigation services. These and other services require a paid or Add-On Plan. Visit onstar.ca for vehicle availability, coverage maps, details and system limitations. Available 4G LTE with Wi-Fi hotspot requires WPA2 compatible mobile device and data plan. Data plans are provided by AT&T. ¹³ Available in 10 Canadian provinces, 3 territories and the 48 contiguous United States. Subscription sold separately after trial period. If you decide to continue your service at the end of your trial subscription, the plan you choose will automatically renew and bill at then-current rates until you call 1-888-539-7474 to cancel. Other fees and taxes will apply. All fees and programming subject to change. See SiriusXM "Terms & Conditions" and complete details at siriusxm.ca. ¹⁴ Not compatible with all devices. ¹⁵ The system wirelessly charges one PMA- or Qi-compatible mobile device. Some devices require an adaptor or back cover. To check for phone or other device compatibility, visit chevrolettotalconnect.ca for details. ¹⁶ Requires available Driver Confidence Package. † All-season tires may not satisfy winter tire requirements in all regions of the country. Tires specifically designed for severe winter conditions and marked with the "winter tire" symbol may be required during certain months or in certain regions. Contact your Provincial, Municipal or local road authority for information regarding which tires are required in your particular area.

SPECIFICATIONS

	LT	PREMIER
SAFETY AND SECURITY		
Airbags		
- driver and front passenger, dual-stage, frontal with Passenger Sensing System and airbag suppression	●	●
- driver and front passenger, seat-mounted side-impact	●	●
- driver and front passenger, knee protection	●	●
- front-to-rear, outboard seating positions, head curtain side-impact	●	●
- rear passenger, outboard seating positions, seat-mounted side-impact	●	●
Door locks - rear doors, child-security	●	●
Forward Collision Alert	-	○ ¹
Forward Automatic Braking - low speed	-	○ ¹
Forward Automatic Braking	-	○ ²
Lane Keep Assist	-	○ ¹
OnStar ³ Guidance Plan for 6 months	●	●
Pedestrian safety signal - automatic audible signal at low speed	●	●
Rear Cross Traffic Alert	-	○ ⁴
Safety restraints		
- 3-point belts for all seating positions, front safety belt pre-tensioners, dual-mode retractors and shoulder belt height adjusters	●	●
- LATCH (Lower Anchors and top Tethers for Children), rear seats	●	●
Security system - content theft alarm, audible/visible, programmable	●	●
Side Blind Zone Alert with Lane Change Alert	-	○ ⁴
StabiliTrak [®] - Electronic Stability Control System	●	●
Teen Driver - customizable vehicle features	●	●
Theft-deterrent system - electronic immobilizer	●	●
Traction control - electronic, full-function, all-speed	●	●

● STANDARD ○ AVAILABLE - NOT AVAILABLE

	LT	PREMIER
MECHANICAL		
Battery		
- 120-volt charge cord with 8-amp/12-amp switch	●	●
- accessories, 12-volt with run-down protection	●	●
- charge control, programmable GPS-enabled, location-based	●	●
- propulsion, 18.4-kWh lithium-ion rechargeable Energy Storage System; includes liquid thermal management system with active control	●	●
Brakes		
- electro-hydraulic 4-wheel disc with regenerative braking system on front brakes	●	●
- 4-wheel Anti-lock Braking System (ABS)	●	●
- Regen on Demand, driver-initiated regenerative braking, steering wheel-mounted	●	●
Drive - front-wheel	●	●
Drive mode control switch - Normal, Sport, Mountain and Hold modes	●	●
Electric drive unit - Volt [®] with 149 horsepower (111 kW) motoring power, 294 lb.-ft. of motoring torque	●	●
Range extender - 1.5L DOHC I-4 with VVT and Direct Injection, 101 horsepower (75 kW)	●	●
Exhaust system - aluminized stainless steel with hidden outlet	●	●
Steering - power, electric, rack-and-pinion, variable-assist	●	●
Suspension - front MacPherson strut/rear compound crank	●	●
Transmission - electric drive unit, continuously variable	●	●
EXTERIOR		
Glass - solar-absorbing, tinted	●	●
Lighting		
- daytime running lamps, LED with exterior automatic lamp control	●	●
- headlamps, LED low beam and halogen high beam	●	●
- IntelliBeam automatic high beam on/off	-	○ ¹
- tail lamps, LED	●	●
Mirrors - power remote control, heated	●	●
Parking assist - automatic, includes front, rear, parallel and perpendicular	-	●
Spoiler - rear deck-lid	●	●
Tires		
- P215/50R17 all-season ¹ low rolling resistance tires	●	●
- tire inflator kit	●	●
Wheels		
- 17" x 7" 5-spoke painted-aluminum	●	-
- 17" x 7" split 5-spoke Ultra Bright machined-finish aluminum	-	●
Windshield wipers - 2-speed with variable delay (intermittent)	●	●

	LT	PREMIER
INTERIOR		
Assist handles - rear outboard	●	●
Cargo area - cover	●	●
Climate control		
- automatic, single-zone climate control with cabin preconditioning	●	●
- rear floor heating and cooling ducts	●	●
Console - front floor with covered storage, front and rear dual cupholders and rear 12-volt power outlet	●	●
Cruise control		
- electronic, steering wheel-mounted controls	●	●
- Adaptive Cruise Control, automatically adjusts speed and maintains a pre-set following distance with steering wheel-mounted controls (includes Forward Automatic Braking)	-	○ ⁵
Defogger - electric rear-window	●	●
Floor mats - front and rear, carpeted	●	●
Instrumentation		
- digital cluster, 8-in. reconfigurable colour LCD screen (includes Driver Information Centre, compass, oil life monitoring system, tire pressure monitoring system, engine generator fuel efficiency, vehicle programmable features and message centre)	●	●
- centre 8-in. reconfigurable colour touch-screen with efficiency display	●	●
Lighting		
- ambient LED-based dome, delayed entry/exit, theatre dimming, roof courtesy, front reading lights and incandescent rear cargo area	●	●
- ambient light pipes in front doors	-	●
Locks		
- power, programmable with lock-out protection	●	●
- Keyless Open and Start includes door unlock/lock entry, rear hatch passive opening, keyless Push-Button Start and panic feature	●	●
Mirror		
- rear-view, manual day/night	●	-
- rear-view, auto-dimming	-	●
Power outlets - two, 12-volt auxiliary located in front storage bin and rear of centre console	●	●
Rear vision camera	●	●
Retained accessory power	●	●
Steering column - tilt and telescopic adjustable	●	●
Steering wheel		
- 3-spoke leather-wrapped, includes leather-wrapped shifter	●	●
- Bluetooth ^{®6} cruise and audio system controls	●	●
- heated	●	●

	LT	PREMIER
INTERIOR (CONTINUED)		
Sunshades		
- LH and RH padded, vanity mirrors	●	-
- LH and RH padded, illuminated vanity mirrors, sliding	-	●
Windows - power, driver express-up/down, express-down all other windows and rear-window lock-out features	●	●
Vehicle starter system - remote	●	●
SEATS		
Reclining front bucket seats with adjustable head restraints		
- with premium cloth seating surfaces	●	-
- with leather-appointed seating surfaces	○	●
Manual 6-way driver-seat adjuster	●	●
Manual 6-way front-passenger seat adjuster	●	●
Heated front bucket seats	●	●
Heated rear outboard seats	-	●
Seatback - rear, 60/40 split-folding	●	●
INFOTAINMENT		
Chevrolet MyLink ⁷ Radio with 8-in. diagonal colour touch-screen display, AM/FM stereo, Bluetooth audio streaming ⁶ for select phones, voice-activated technology, Siri Eyes Free ⁸ and Android Auto [™] and Apple CarPlay [™] compatibility ⁹	●	●
Chevrolet MyLink ⁷ Radio with Navigation ¹⁰ and SiriusXM [™] Traffic ¹¹ with 3-month trial	-	○
OnStar 4G LTE and built-in Wi-Fi [®] hotspot ³ for up to seven devices, includes data plan trial for 3 months or 3 GB (whichever comes first)	●	●
OnStar Basic Plan ¹² for 5 years	●	●
6-speaker audio system	●	-
8-speaker premium Bose [®] Energy Efficient Series audio system with subwoofer	○	●
Bluetooth [®] wireless technology and audio streaming ⁶ for select phones	●	●
SiriusXM satellite radio ¹³ with 3-month trial	●	●
USB ports ¹⁴ - two	●	●
Wireless charging ¹⁵	-	●
AVAILABLE PACKAGES		
Driver Confidence Package - includes Side Blind Zone Alert, Lane Change Alert and Rear Cross Traffic Alert	-	○
Driver Confidence II Package - includes Forward Collision Alert, Lane Keep Assist, low-speed Forward Automatic Braking, Following Distance Indicator and IntelliBeam automatic high beam on/off	-	○ ¹⁶



EXTERIOR COLOURS



G1E – SIREN RED TINTCOAT¹



G1W – IRIDESCENT PEARL TRICOAT¹



GA6 – HEATHER GREY METALLIC



GAN – SILVER ICE METALLIC



GAZ – SUMMIT WHITE



GB8 – MOSAIC BLACK METALLIC



GD1 – KINETIC BLUE METALLIC¹



GMU – PEPPERDUST METALLIC

WHEELS



17" 5-Spoke Painted-Aluminum
(Standard on LT)



17" Split 5-Spoke Ultra Bright
Machined-Finish Aluminum
(Standard on Premier)

¹ Available at extra cost. ² Standard on LT. ³ Available on LT. ⁴ Standard on Premier.

INTERIOR FABRICS



Jet Black Premium Cloth with Jet Black Accents²



Dark Ash Grey Premium Cloth with Light Ash Grey Accents²



Jet Black Leather-Appointed Seating with Jet Black Accents^{3,4}



Light Ash Grey Leather Appointments with Dark Ash Grey Accents^{3,4}



Brandy Leather Appointments with Jet Black Accents⁴



COMPLETE CARE

Experience Chevrolet Complete Care, a comprehensive coverage, warranty and protection program that comes standard with every new 2017 Chevrolet Volt lease and purchase. Simply, it is designed around you, to make it easy to keep your Chevrolet like new – and give you the confidence you deserve when you need it most. Please visit chevrolet.ca or see your dealer for full details.

YOUR COMPREHENSIVE OWNER BENEFIT PROGRAM.

2-year/48,000 km¹ Complimentary Oil Changes²

3-year/60,000 km¹ New Vehicle Limited Warranty

5-year/160,000 km¹ Powertrain Component Limited Warranty, with \$0 deductible on repairs and the warranty is fully transferable at no charge

5-year/160,000 km¹ Courtesy Transportation

5-year/160,000 km¹ 24/7 Roadside Assistance

6-year/160,000 km¹ rust-through perforation coverage

8-year/130,000 km¹ coverage on catalytic converters and Powertrain Control Modules (PCMs)

8-year/160,000 km¹ Volt battery and Voltec Component Limited Warranty³

OnStar⁴ Guidance Plan for 6 months, including Automatic Crash Response, Stolen Vehicle Assistance, Roadside Assistance and Turn-by-Turn Navigation (trial excludes Hands-Free Calling minutes)

OnStar Basic Plan⁵ for 5 years on most Chevrolet vehicles, including select myChevrolet mobile app services⁶

OTHER OWNERSHIP PRIVILEGES AND PROGRAMS⁷

• GM Protection Plan (GMPP) – the only extended service plan backed by the resources and commitment of General Motors, GMPP may be purchased at the time of sale or subsequently during the New Vehicle Limited Warranty period.

• Chevrolet Certified Service – to help your Chevrolet vehicle live up to its performance promise, Chevrolet Certified Service – found exclusively at your Chevrolet dealer – is there. With all the engineering excellence in your vehicle, GM-trained technicians have the expertise to care for all of it.

• Chevrolet Owner Centre – as an owner, take advantage of the Chevrolet Owner Centre. This online owner's destination gives you

access to contests, current offers and the latest driving and maintenance tips. Find out more at chevroletowner.ca.

TO HELP YOU PURCHASE OR LEASE A NEW VEHICLE

- Purchase Financing and Leasing – on-the-spot financing; see dealer for full details.⁸
- GM Student Bonus Program – students or recent graduates of high school, college or university⁸ may be entitled to receive a Student Bonus Vehicle Redemption Allowance of \$500 or \$750⁷ (tax inclusive) (purchased vehicle dependant) to use towards the purchase, lease or finance of one eligible new Chevrolet vehicle.
- GM Card⁸ – cardholders may redeem Earnings towards the total purchase price or lease down payment of an eligible new Chevrolet car, truck or crossover. Restrictions and limitations apply. For full program details, visit gmcards.ca.

INFORMATION RESOURCES You can find more information about these programs from your Chevrolet dealer, or at these information centres:

- The Chevrolet website at chevrolet.ca
- The GM Customer Care Centre at 1-800-GM-DRIVE (1-800-463-7483 or 1-800-263-3830 for TDD users).

A WORD ABOUT THIS BROCHURE Some of the equipment shown or described throughout this brochure may be available at extra cost. We have tried to make this brochure comprehensive and factual. We reserve the right, however, to make changes at any time, without notice, in prices, colours, materials, equipment, specifications, models and availability. Specifications, dimensions, measurements, ratings and other numbers in this brochure and other printed materials provided at the dealership or affixed to vehicles are approximates based upon design and engineering drawings and prototypes and laboratory tests. Your vehicle may differ due to variations in manufacture and equipment. Since some information may have been updated since the time of printing, please check with your Chevrolet dealer for complete details. General Motors of Canada Company reserves the right to lengthen or shorten the model year for any product, for any reason, or to start and end model years at different times. Certain vehicle features may lose their usefulness over time due to obsolescence from technological changes. Unless otherwise noted, all claims based on the latest available competitive information. Excludes other GM vehicles.

ENGINES Chevrolet products are equipped with engines produced by GM Powertrain or other suppliers to GM worldwide. The engines in Chevrolet products may also be used in other GM makes and models.

ASSEMBLY Chevrolet vehicles and their components are assembled or produced by different operating units of General Motors, its subsidiaries or suppliers to GM worldwide. We sometimes find it necessary to produce Chevrolet vehicles with different or differently sourced components than originally scheduled. Since some options may be unavailable when your vehicle is assembled, we suggest you verify that your vehicle includes the equipment you ordered and that, if there were changes, they are acceptable to you.

TRADEMARKS The marks appearing in this brochure including, but not limited to, General Motors, GM, Chevrolet, the Chevrolet emblem, Volt and their respective logos, emblems, slogans and vehicle model names and body designs; and other marks such as Find New Roads, IntelliBeam, myChevrolet, MyLink, OnStar, the OnStar emblem, Regen on Demand, StabiliTrak and Voltec are trademarks of General Motors LLC and/or General Motors of Canada Company, its subsidiaries, affiliates or licensors. Apple, Apple CarPlay, iPad, iPhone, iPod, iTunes and Siri are trademarks of Apple Inc., registered in the U.S. and other countries. Bluetooth is a registered trademark of Bluetooth SIG, Inc. Bose is a registered trademark of the Bose Corporation. Facebook is a registered trademark of Facebook Inc. Michelin is a registered trademark and Energy is a trademark of Michelin North America, Inc. © 2016 SiriusXM Canada Inc. "SiriusXM," the SiriusXM logo, channel names and logos are trademarks of Sirius XM Radio Inc. and are used under license. All rights reserved. Twitter is a trademark of Twitter, Inc. YouTube is a registered trademark and Android and Android Auto are trademarks of Google Inc. Wi-Fi is a registered trademark of Wi-Fi Alliance.

COPYRIGHT © Copyright 2016 General Motors of Canada Company. All rights reserved. All text, images, graphics, and other materials in this brochure are subject to the copyright and other intellectual property rights of General Motors LLC and/or General Motors of Canada Company. These materials may not be reproduced, distributed or modified without the express written permission of General Motors LLC and/or General Motors of Canada Company. Printed in USA, September 2016

¹ Whichever comes first. Conditions and limitations apply. See dealer for details. ² Limit of four complimentary Lube-Oil-Filter services in total. Fluid top-offs, inspections, tire rotations, wheel alignments and balancing, etc., are not covered. Conditions and limitations apply. See dealer for details. ³ The Volt battery warranty covers battery components in addition to the thermal management system, charging system and electric drive components. ⁴ Visit onstar.ca for coverage maps, details and system limitations. Service plan required. Available 4G LTE with Wi-Fi hotspot requires WPA2 compatible mobile device and data plan. Data plans provided by AT&T. Services vary by model, service plan, conditions as well as geographical and technical restrictions. OnStar with 4G LTE connectivity is available on select vehicle models and in select markets. Vehicle must be started or in accessory mode to access Wi-Fi. ⁵ The OnStar Basic Plan is available for 5 years from the delivery date of the eligible new 2017 model year vehicles to the original owner and is transferable to subsequent owners for the remaining term. It includes the monthly Diagnostics Report emails (capabilities vary by model), Dealer Maintenance Notification, access to select vehicle mobile app features and more. This plan does not include emergency, security or navigation services. These and other services require a paid or Add-On Plan. Visit onstar.ca for vehicle availability, coverage maps, details and system limitations. Available 4G LTE with Wi-Fi hotspot requires WPA2 compatible mobile device and data plan. Data plans are provided by AT&T. ⁶ Available on select Apple and Android devices. Some features may require a paid OnStar service plan. Features and capability may vary by vehicle, device, conditions as well as geographical and technical restrictions. Device data connection required. ⁷ Conditions and limitations apply. ⁸ Subject to eligibility.

DEALER ePROCESS